



HYDRAULIC RGN

We have heard your calls!

After years of requests from our dedicated customers, Doonan has entered the Hydraulic RGN market.



- **BUILT USING OUR HISTORICALLY TESTED 35-TON MECHANICAL RGN TRAILER FRAMES**
- **THE FIRST IN OUR SERIES OF 35-TON TO 55-TON HYDRAULIC RGN TRAILERS**

OPTIONAL FLIP AXLE

- Larger load rating



ON-BOARD PONY MOTOR AND HYDRAULICS

- Raise and lower the deck height of the trailer
- Quickly attach/detach Gooseneck and trailer

800-734-0608

www.doonan.com

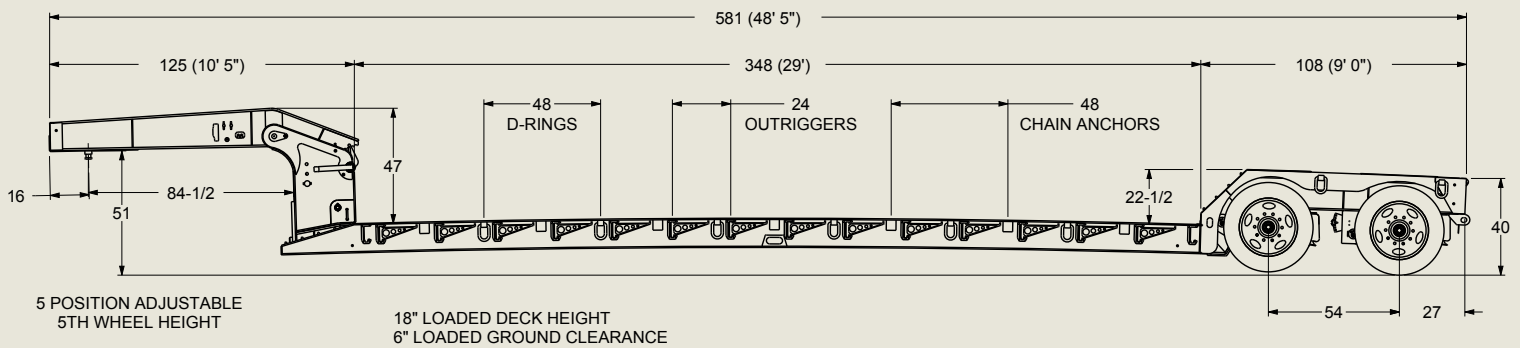

5 POSITION ADJUSTABLE
5TH WHEEL HEIGHT

18" LOADED DECK HEIGHT
6" LOADED GROUND CLEARANCE

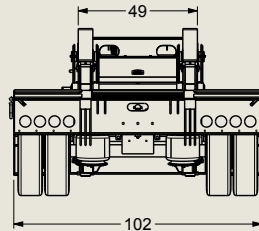

HYDRAULIC RGN

	UNLESS OTHERWISE SPECIFIED TOLERANCES ARE: HOLE DIA +0.015 0 STRAIGHT LENGTH ±.18 ANGLES ±.1 DEG.		THIRD ANGLE PROJECTION	
	SCALE	0.034	DATE VERIFIED	SHEET SIZE
PART NAME	48' 6" HYD RGN 54" SP, 3/4" FL	ENGINEERED BY	MWH	DATE DRAWN
		DOWNLOAD NUMBER	492YBBIZZGCA-WELD	EST. WT. LBS
		PART NUMBER	492YBBIZZGCA-WELD	SHEET
				2/5

STRUCTURE

Beam Rating	70,000 lbs in 16 feet
Overall Length	48' 5"
Top Deck Length	10' 5"
Main Deck Length	29' 0"
Rear Deck Length	9' 0"
Width	102 inches
Flange - Inner Beam	3/4" x 7" minimum 130k grade material
Flange - Outer Beam	1/2" x 6" minimum 130k grade material
Inner Beams	Two (2) 12" deep manufactured beams with 1/4" web (minimum 50k grade web material)
Outer Beams	Two (2) 12" deep manufactured beams with 1/4" web (minimum 50k grade web material)
Cross Sill Height	6" & 4" alternating crossmembers on 12" centers
Side Rail	Outer perimeter beam with 4 pair D-rings - Custom Quantities Available
Neck	Narrow neck with 5 position adjustable fifth wheel height (46 1/2" - 51")
Rear Deck Height	40 inches
Main Deck Height	18 inches (when loaded)
Swing Clearance	84 inches
King Pin Setting	16 inches
Outriggers	None Standard - Custom Quantities Available
Chain Anchors	None Standard - Custom Quantities Available
Flooring	TOP: None, WELL: 1 3/8" Apitong, REAR: 1 3/8" Apitong
Paint	Black - 2 part epoxy primer and top coat applied after shot blasting

AXLES & SUSPENSIONS

Suspension Type	Hendrickson HT250 Air-ride Suspension
Number of Axles	2 axles - 25,000 lb nominal with 77.5 tracking
Axle Spacing	54 inches - set to the rear
Axle Spindle	Tapered Spindle
Lift Axle Kits	None Standard
Hub & Drums	Cast hub with outboard cast drums
Bearing Lubricant	Oil in hubs
Outer Wheels	22.5" x 8.25" Steel - Prepainted White
Inner Wheels	22.5" x 8.25" Steel - Prepainted White
Tires	General ST250 255/70R22.5
Spare Wheel & Tire	None Standard
Tire Carrier	None Standard
Tire Inflation System	None Standard
Mudflaps	Single Pair At Rear
RGN - Power Source	13 HP Honda Motor (Wet Kit Option Available)
ABS	Wabco 4S/2M
Brakes	Spring brakes with auto slack adjusters
Brake Dust Covers	None Standard
Light Kit	Standard Grote LED
Clearance Lights	3 MicroDot Clearance Lights Per Side
Rear Lights	4-3-4 Standard LED Lights
Conspicuity Tape	Per NHTSA spec
Flag Holders	None Standard
Certificate Holder	None Standard
FHWA Inspection	None Standard

Weight

17,450 lbs

36 NE Highway 156 • Great Bend, Kansas 67530 • Telephone (620) 792-6222 • Fax (620) 792-3308

Not all options are compatible with other option combinations. Custom options are available upon request. Doonan Specialized Trailer, LLC reserves the right to make changes in material, components, design, equipment specifications and trailer models without notice. All visual specifications, representations, and dimension references are based on the latest product offering and are approximations available at the time of publication. At no time will the information contained within this publication be used as a basis for resolving disputes.